

1. Characteristics:

- 1.1 Long period stability.
- 1.2 Widely detecting scope.

2. Application

Family and industry use

Suitable for detecting of Smoke、SO₂、CO₂、isobutane、alcohol...etc.

3. Property

A. Standard work condition

symbol	parameter name	Technical condition	remarks
Vc	circuit voltage	5V	AC OR DC
VH	Heating voltage	5V	AC OR DC
PL	load resistance	can adjust	Ps
RH	heater resistance	33 Ω ±5%	room Temp
PH	heating consumption	less than 800mw	

B. Environment condition

symbol	parameter name	technical condition	remarks
Tao	Operating Temp	-20℃-50℃	
Tas	storage Temp	-20℃-70℃	
RH	Operating humidity range	less than 95%Rh	
O2	oxygen concentration	21%(standard condition) Oxygen concentration affect sensitivity	minimum value is over 2%

C. Sensitivity characteristic

Symbol	parameter name	technical parameter	remark 1	ramark 2
Rs	sensing body resistance	1K Ω -10K Ω (1000ppm isobutane)	suitable for 3000ppm LPG and propane	detecting concentration scope: 1%~10% smoke 0.3~20% CO ₂ 300ppm-5000ppm isobutane
α (3000/1000) isobutane	concentration slope rate	≤0.6		
standard detecting condition	Temp: 20℃ ±2℃ Vc:5V±0.1 Humidity: 65%±5%RH Vh: 5V±0.1			
preheat time	over 24 hours			

D. Machinery characteristic

project	condition	property
vibration	ferquency 100Hz	should be conformed to given sensitivity characteristic
	vertical vibrating amplitude	
	time 1 hour	
punch	acceleration 100G	
	punch times 5	

4. Sensitivity characteristic curve of HS-135 air pollution sensor as follow:

Fig 1 is relation curve of VRL and gas concentration.

At:Temp: 20°C 、 Humidity: 65%RH、 O2=concentration 21% RL=5k Ω

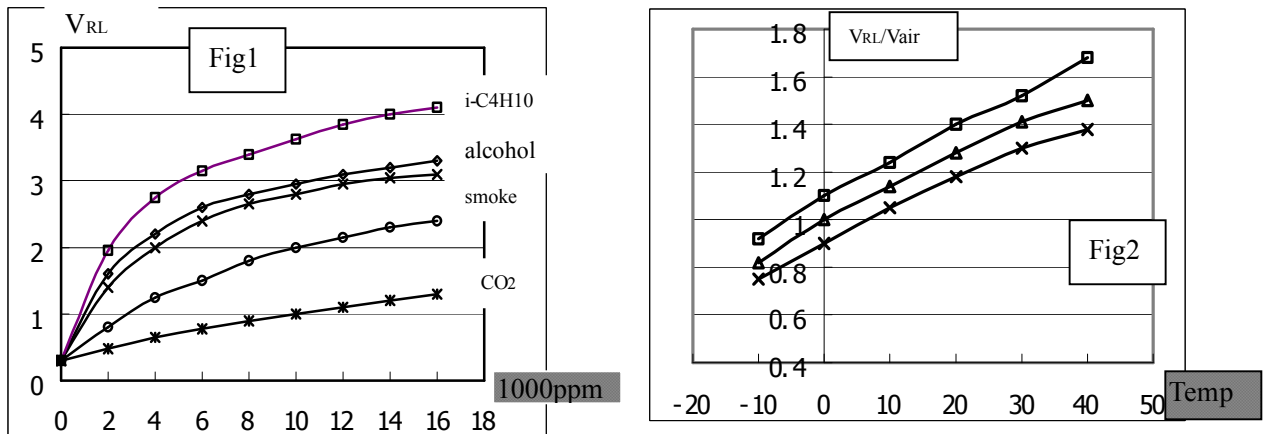

Fig 2 is relation between surface resistance of HS-135 with environment related humidity.

5. HS-135 structure and circuit symbols(Fig 3).

series	parts	materials
1	sensing layer	SnO2
2	measurement electrode	Au
3	measurement electrode ignited wire	Pt
4	heater	N1-Cr alloy
5	tubular ceramic basic body	Al 2O3 ceramic
6	anti-explosion network	100 dual layer stainless steel (SUS316)
7	clamp ring	Ni plating
8	basic seat	bakelite
9	tube foot	CP wire

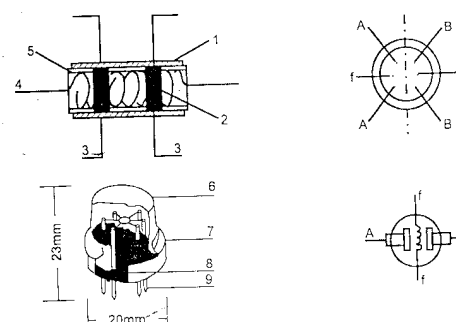

Fig3

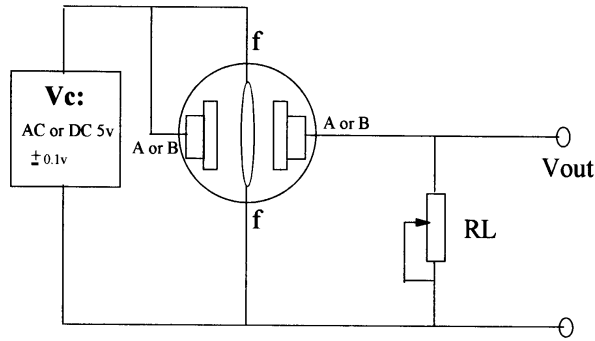

Fig4

Fig:2

6. Electric parameter measurement circuit

Fig 4 is standard test circuit of HS135.

As environment temperature and humidity will effect to sensor sensitivity. So. when accurately measuring, must consider environment factor.

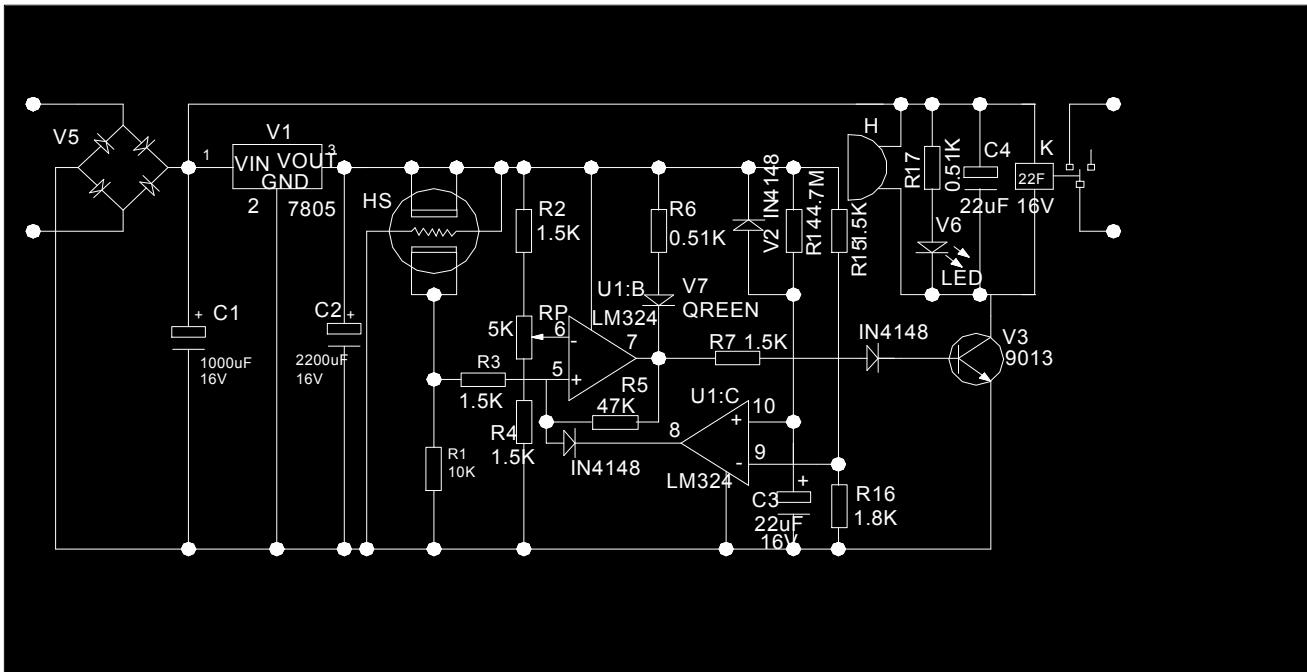

Fig 5 Is the reference circuit which have temperature compensation function.

7. Sensitivity adjustment

Resistance value changing of HS-135 will be exist in every pieces and difference gas environment. So, when check the sensor sensitivity, we suggest that use 300ppm-1000ppm isobutane $\langle \text{C}_4\text{H}_{10} \rangle$ as sensitivity adjustment standard gas.

Adjustment steps:

- Input sensor to application circuits.
- If the sensor is first time to be use, we suggest the preheating time will not be less than 24 hours. In order to guarantee sensitive can reach stability completely.
- In the detecting gas concentration, adjusting load resistance R_L until the suitable signal output.