



GAS SENSORS : TYPE AF30

CIGARETTE SMOKE SENSOR

DESCRIPTION:

Gas sensor made with thick film element.

FEATURES:

- Constant heater voltage
- Tight resistance tolerance
- High sensitivity
- Typical applications include air purifier

DATA:

Operating conditions:

Operating temperature -10 to +55°C

Storage temperature -30 to +60°C

Load Resistor R_L Variable

Heater resistance 27Ω (nom)

Rated power consumption P_s < 15mW

Rated working voltage of circuit V_c
 5V d.c. or 5V rms a.c. (max 12V)

Rated working voltage of heater
 5 ± 0.2V d.c.
 5 ± 0.2 V rms a.c.

Parts and material:

Sensing element Semi-conducting oxide

Thick film heater Platinum

Case Nylon 66

Pin Nickel alloy

Flame arrestor
 ... Double 100-mesh stainless gauze (SUS316)

DIMENSIONS:

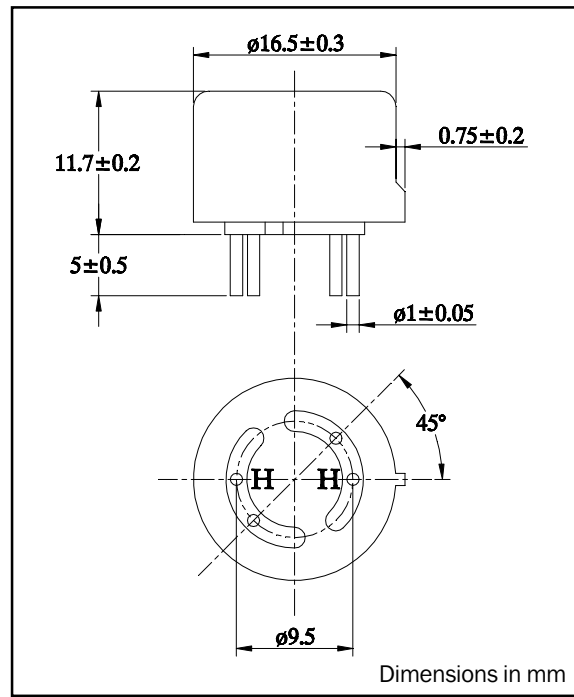

Typical gas sensitivity:

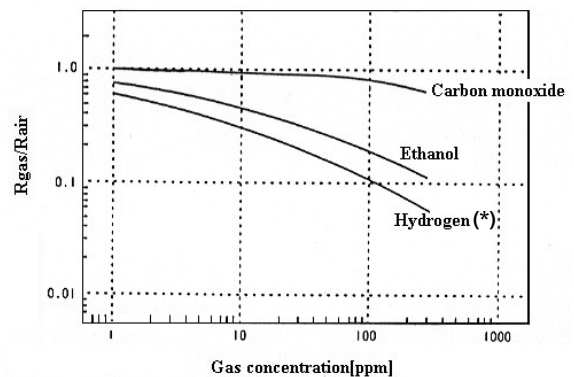

(*) Correlation between H₂ and cigarette smoke

Sensitivity characteristics:

	Specification	Conditions
Sensor resistance R_{gas}	15k to 35k Ω	In clean air
Gas sensitivity R_{gas}/R_{air}	0.2 to 0.4	Resistance ratio at 10ppm H ₂ to clean air (*)
Power consumption	535mW (max)	

Mechanical characteristics:

Test	Condition	Performance
Vibration	Frequency: 10 - 500 Hz Amplitude (10 - 50Hz): 2 mm Acceleration (50 - 500 Hz): 10G Reciprical scanning time: 5 min Test time: 2 hours each for X, Y and Z directions	Should satisfy the specifications shown in the sensitivity characteristics
Shock	Acceleration: 100G Number of impacts: 5	

Data sheet D-AF30-1



GAS SENSORS : TYPE AF30

SMOKE SENSOR

NOTES:

Pin allocation and standard test circuit:

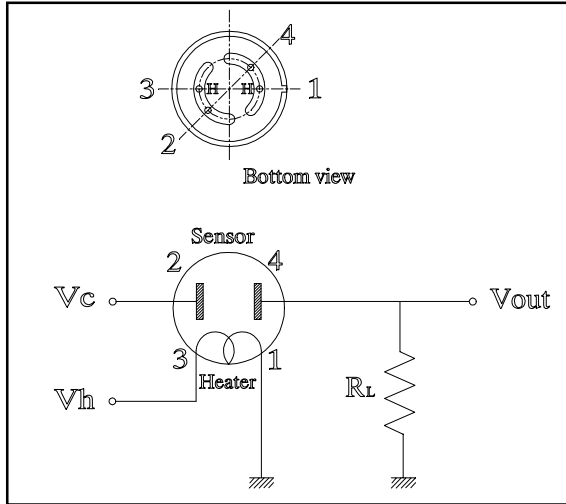

Test conditions:

Atmosphere

Clean air at $25 \pm 2^\circ\text{C}$ and $50 \pm 5\%$ RH without noise gas.

Circuit condition

Vc (circuit voltage) $5 \pm 0.05\text{V}$

Vh (heater voltage) $5 \pm 0.05\text{V}$

Preheat time 48 hours

Test gas

Hydrogen 10ppm

WARNING:

Do not use if the case or wire netting is damaged, otherwise built-in heater may cause explosions or fires.
Do not disassemble or change any parts.
Use only within specified conditions.